



- Dispositivo tradizionale di fresatura per ACM
- Grooving device for ACM
- Dispositif classique de rainurage ACM
- Traditionnell Anbau zum fraesen ACM
- Dispositivo tradicional para ranura ACM



- Dispositivo "SCU" con avanzamento manuale
- "SCU" device with manual feed
- Dispositif "SCU" avec alimentation manuelle
- "SCU" Garaet mit manueller Zufuehrung
- Dispositivo "SCU" con alimentacion manual

Dispositivo piccoli pannelli 50 cm o 100 cm - Device for small panels 50 cm or 100 cm - Dispositif pour petits panneaux 50 cm ou 100 cm - Dispositivo para paneles pequenos 50 cm o 100 cm - Vorrichtung fuer kleine Paneele von 50 cm oder 100 cm

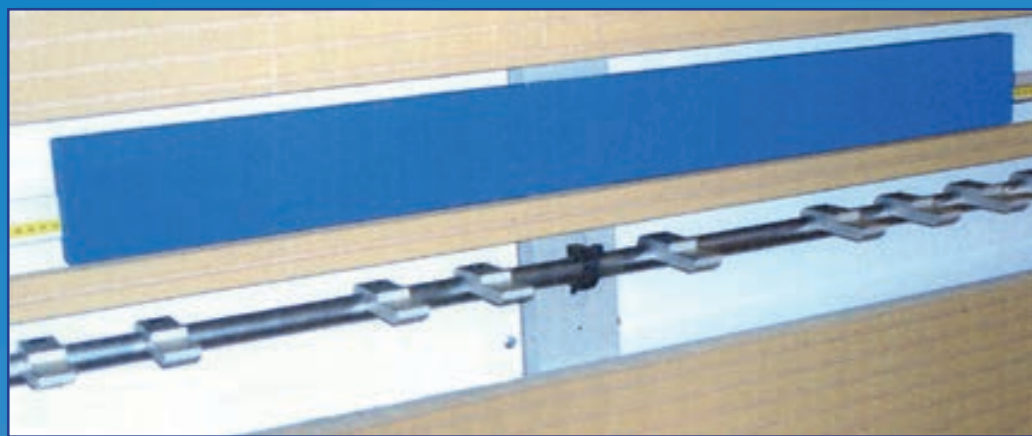

- Visualizzatore per tagli orizzontali a cristalli liquidi
- Liquid crystal display (LCD) for horizontal cuts
- Afficheur à cristaux liquides pour coupes horizontales
- Visualizador de cristales líquidos para cortes horizont.
- Flüssigkristall-Anzeige sichtgerat fuer horizontale Schnitte



- Visualizzatore per tagli verticali a cristalli liquidi
- Liquid crystal display (LCD) for vertical cuts
- Afficheur à cristaux liquides pour coupes verticales
- Visualizador de cristales líquidos para cortes verticales.
- Flüssigkristall-Anzeige sichtgerat fuer vertikale Schnitte

A NEW GENERATION KGS/GMC 4-ALU M



G.M.C. s.r.l.

- SEZIONATRICE VERTICALE MANUALE PER TAGLIO E FRESATURA PANNELLI IN ALLUMINIO COMPOSITO
- MANUAL VERTICAL PANEL SAW TO CUT AND GROOVE ALUMINIUM COMPOSITE PANELS
- SCIE A PANNEAUX VERTICAL MANUELLE POUR LE DECOUPAGE ET RAINURAGE DES PANNEAUX COMPOSITES EN ALUMINIUM
- MANUELLE VERTIKALPLATTENSAEGE FUER DAS SCHNEIDEN UND FRAESEN VON ALLUMINIUM VERBUNDPLATTEN
- SECCIONADORA VERTICAL MANUAL PARA CORTAR Y RANURAR PANELES COMPUESTOS DE ALUMINIO

G.M.C. Srl - Via Puglie 21, 41012 Carpi - (MO) Italy - Tel. 059/692163-695785 - Fax 059/641607
Web Site: www.gmc.it - E-mail: gmc@gmc.it

A NEW GENERATION KGS/GMC 400 M KGS/GMC 300 M

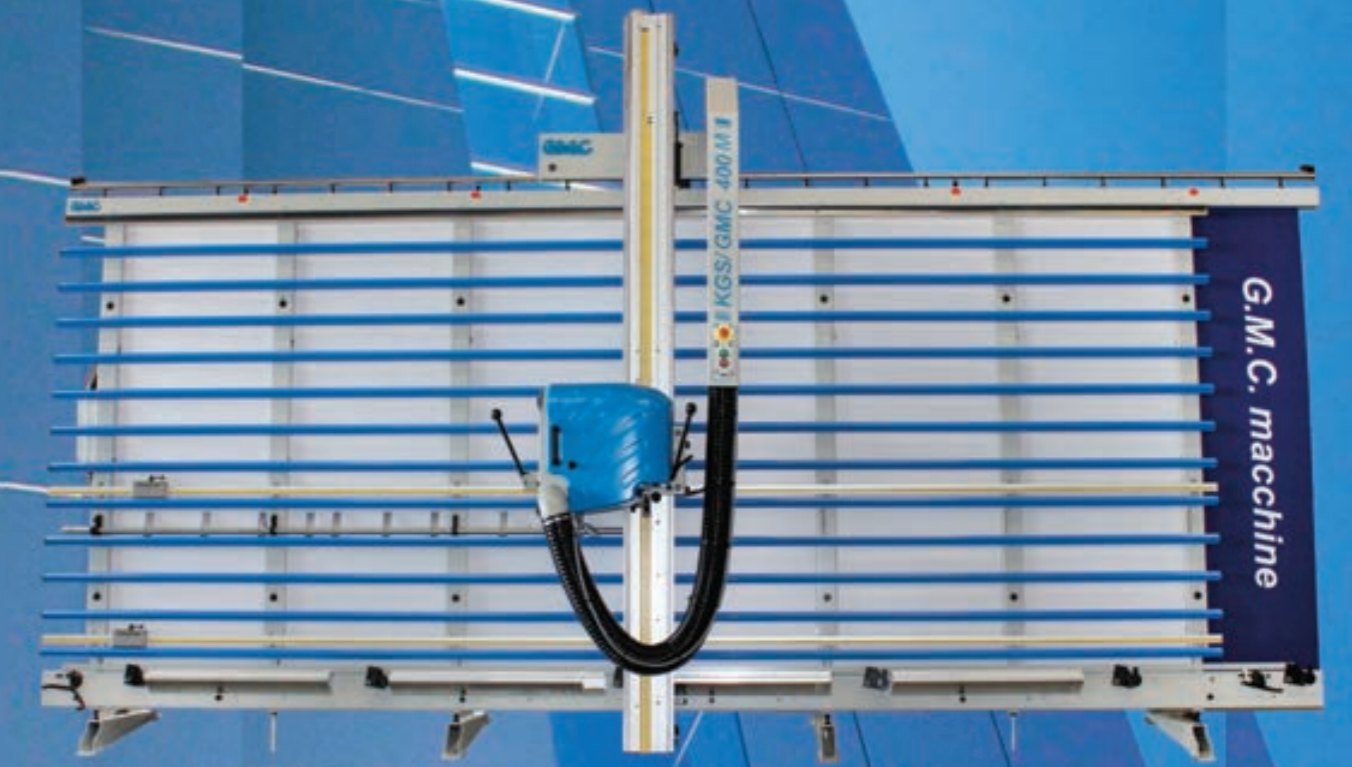

G.M.C. s.r.l.

- SEZIONATRICE VERTICALE MANUALE PER TAGLIO PANNELLI
- MANUAL VERTICAL PANEL SAW TO CUT PANELS
- SCIE A PANNEAUX VERTICAL MANUELLE POUR LE DECOUPAGE DES PANNEAUX
- MANUELLE VERTIKALPLATTENSAEGE FUER DAS SCHNEIDEN VERBUNDPLATTEN
- SECCIONADORA VERTICAL MANUAL PARA CORTAR PANELES

G.M.C. Srl - Via Puglie 21, 41012 Carpi - (MO) Italy - Tel. 059/692163-695785 - Fax 059/641607
Web Site: www.gmc.it - E-mail: gmc@gmc.it

ACCESSORI - ACCESSORIES ACCESSOIRES - OPCIONALES - ZUBEHOERE



- Gruppo incisore
- Scoring unit
- Unité de gravure
- Vorritzaggregat
- Grupo de incisión



- Gruppo incisore con cinghia protetta
- Scoring unit with belt protected
- Unité de gravure avec courroie protégée
- Vorritzaggregat mit geschuetzten Riemen komplett
- Grupo de incisión con correa protegida



- Rulli a scomparsa per spostamento pannelli
- Turnover rollers for the sliding of boards
- Rouleaux escamotables pour le déplacement des panneaux
- Rodillos ocultables para el desplazamiento de los paneles
- Klappbaren und versenkbare Rollen zur Paneele-Verschiebung



- Sistema di aspirazione totale DPS (dust preventer system)
- DPS extraction system. (dust preventer system)
- Système d'aspiration totale DPS (dust preventer system)
- Sistema de aspiración total DPS (dust preventer system)
- Voelliges Absaugsystem DPS (dust preventer system)



- Sistema di aspirazione totale DPS (dust preventer system)
- DPS extraction system. (dust preventer system)
- Système d'aspiration totale DPS (dust preventer system)
- Sistema de aspiración total DPS (dust preventer system)
- Voelliges Absaugsystem DPS (dust preventer system)

DIMENSIONI D'INGOMBRO - OVER ALL DIMENSIONS (MACCHINE MONTATE) - (MACHINES ASSEMBLED)

DIMENSIONS D'ENCOMBRÉ - DIMENSIONES OCUPADAS - AUßENMAßE (MACHINES MONTÉES) - (MAQUINAS MONTADOS) - (MASCHINE AUFGESTELLEN)

Modelli-Models-Modele-Modelos-Modells	(A) mm	(B) mm	(B1) mm con incisore with scoring avec inciseur con incisor mit Vorritzaggregat	(C) mm	(C1) mm con incisore with scoring avec inciseur con incisor mit Vorritzaggregat	(D) mm	(E) mm	(F) mm	(F1) mm con incisore with scoring avec inciseur con incisor mit Vorritzaggregat	(G) mm	(H) mm	Peso Netto Net Weight Poids Net Peso Neto Netto Gewicht kg
KGS/GMC 300 M	4300	2580	2580	2100	2100	800	1500	2550	2550	700	850	590
KGS/GMC 400 M	5300	3000	3000	2400	2400	800	1500	2940	2940	700	850	688
KGS/GMC 4-ALU M	5300	3000	3000	2400	2400	800	1500	2940	2940	700	850	688

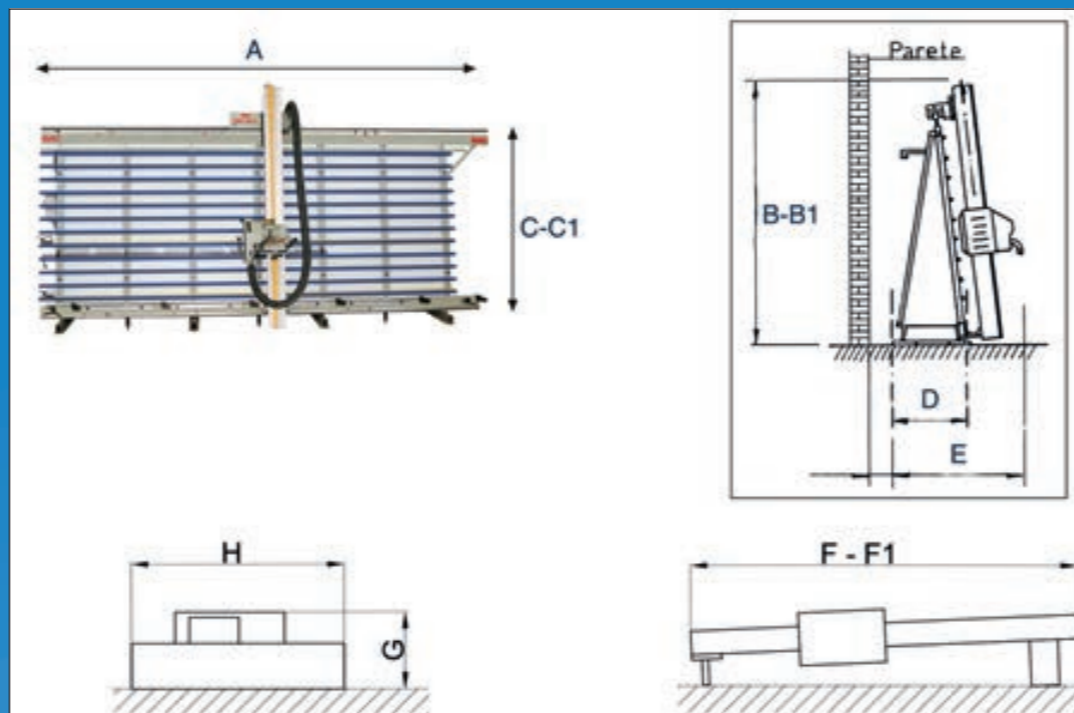

Modelli-Models-Modele-Modelos-Modells	A mm	B mm	C mm	Peso netto kg Net weight Poids Net Peso Neto Netto Gewicht kg	Lordo Gabbia kg Gross weight Crate Poids lourd caisses Peso bruto con caja Brutto Gewicht Kisten kg	Lordo Cassa kg Gross weight Case Poids lourd caisses Peso bruto con cassa Gross Weight Case	D mm	E mm	F mm	Peso netto kg Net weight Poids Net Peso Neto Netto Gewicht kg	Lordo Gabbia kg Gross weight Crate Poids lourd caisses Peso bruto con caja Brutto Gewicht Kisten kg	Lordo Cassa kg Gross weight Case Poids lourd caisses Peso bruto con cassa Gross Weight Case
KGS/GMC 300 M	2650	930	850	250	310	370	2050	4420	350	340	415	620
KGS/GMC 400 M	3060	930	850	268	334	398	2270	5420	350	420	516	710
KGS/GMC 4-ALU M	3060	930	850	268	334	398	2270	5420	350	420	516	710

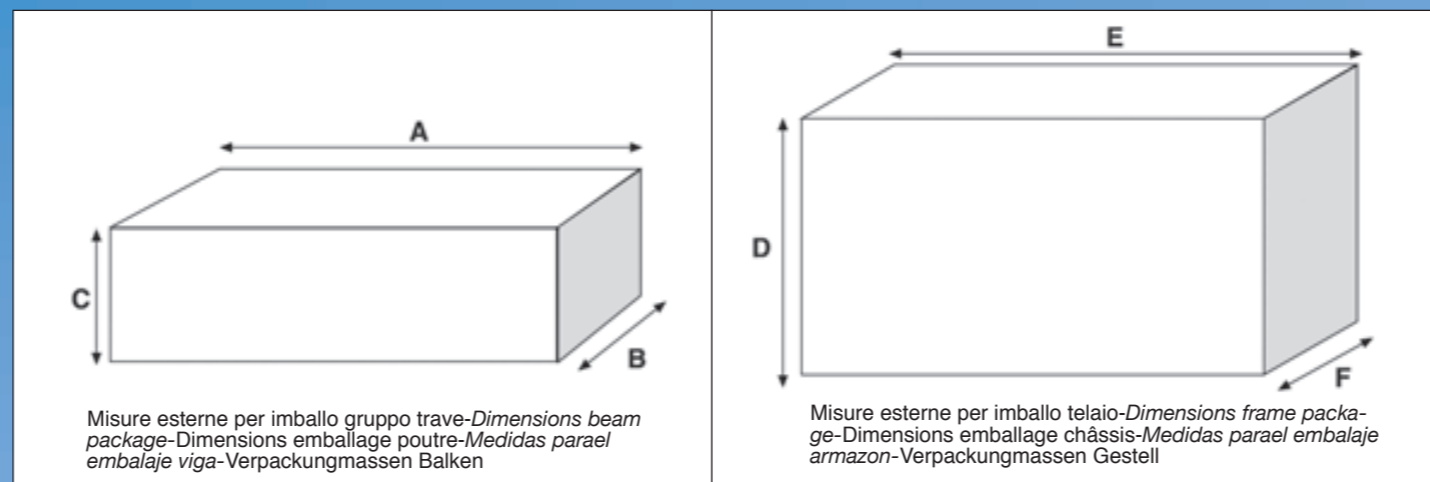

Misure esterne per imballo gruppo trave-Dimensions beam package-Dimensions emballage poutre-Medidas para el embalaje viga-Verpackungsmassen Balken

Misure esterne per imballo telaio-Dimensions frame package-Dimensions emballage châssis-Medidas para el embalaje armazon-Verpackungsmassen Gestell

SU RICHIESTA - ON REQUEST
SUR DEMANDE - BAJO PEDIDO
AUF WUNSCH

S DI SERIE - STANDARD
STANDARD - DE SERIE
SERIENMÄSSIG

- NON APPLICABILE - NOT APPLICABLE
NON APPLICABLE - NO APPLICABLE
NICHT ANWENDBAR

Modelli-Models-Modele-Modelos-Modells	KGS/GMC 4-ALU M	KGS/GMC 400 M	KGS/GMC 300 M	DATI TECNICI - TECHNICAL DATA - DONNEES TECHNIQUES - TECHNISCHE ANGABEN - DATOS TECNICOS	KGS/GMC 4-ALU M	KGS/GMC 400 M	KGS/GMC 300 M
Dispositivo "SCU" di taglio fresatura ACM "SCU" device cutting grooving ACM Dispositif "SCU" de coupe rainurage ACM Dispositivo "SCU" de corte ranura ACM "SCU" Vorrichtung zum schneiden fraesen ACM	#	#	#	Lunghezza taglio orizzontale - Length of horizontal cut - Coupe utile horizontal - Schnitt laenge - Longitud maxima de corte	4200 mm	4200 mm	3200 mm
Dispositivo di fresatura tradizionale ACM Traditional ACM grooving device Dispositif rainurage traditionnel ACM Dispositivo de ranura tradicional ACM Vorrichtung zum herköm. fraesen ACM	#	#	#	Altezza taglio verticale - Height of vertical cut - Coupe utile vertical Schnitt Hoehe - Altura maxima de corte	2200 mm	2200 mm	1900 mm
Dispositivo "MFP" "MFP" device Dispositif "MFP" Dispositivo "MFP" Vorrichtung "MFP"	-	#	#	Max altezza di taglio orizzontale - Max height of horizontal cut - Max hauteur de coupe horizontal - Max horizontal Schnitt Hoehe - Max altura corte horizontal	2070 mm	2070 mm	1650 mm
Frese diametro 110 per SCU a 90° / 135° / U 110 diameter grooving cutters for SCU at 90° / 135° / U Fraises diametre 110 pour SCU A 90° / 135° / U Fresas diámetro 110 para SCU A 90° / 135° / U Fräsen Durchmesser 110 für SCU 90° / 135° / U	#	#	#	Max altezza di fresatura / incisore verticale - Max height of vertical grooving / scoring - Max hauteur de gravure / inciseur vertical - Max Hoehe Vertikale Fraesen / Gravierm - Max altura de ranura / incision vertical	2200 mm 2140 mm*	2200 mm 2140 mm*	1900 mm 1650 mm*
Frese diametro 250 90° / 135° / U 250 diameter grooving cutters 90° / 135° / U Fraises diametre 250 90° / 135° / U Fresas diámetro 250 90° / 135° / U Fräsen Durchmesser 250 90° / 135° / U	#	#	#	Spessore di taglio - Depth of cut - Profondeur de coupe - Schnittiefe Espesor maximo de corte	60 mm	60 mm	60 mm
Rulli scorrimento pannelli Panel sliding rollers Rouleaux de glissement des panneaux Rodillos de deslizamiento paneles Gleitrollen tafeln	#	#	#	Potenza del motore - Motor HP - Moteur HP Motor HP - Potencia del motor	4 hp	4 hp	4 hp
Telaio mobile automatico Automatic moving frame Châssis mobile automatique mécanique Bastidor móvil automatico mecanico Beweglicher rahmen automatish mechanisch	-	S	S	Diametro lama principale - Diameter main saw blade - Diametre lame principal - Durchmesser Kressae Geblat - Diametro sierra principal	250 mm	250 mm	250 mm
Telaio mobile pneumatico Automatic pneumatic moving frame Châssis mobile automatique pneumatique Bastidor móvil automatico neumático Beweglicher rahmen automatish pneumatish	-	#	#	Giri della lama principale - Circular saw speed - Tour de la scie principal Drehzahl Saegeblatt - Regimen eje sierra	5100 U/min'	5100 U/min'	5100 U/min'
Motore HP 6 6 HP motor Moteur HP 6 Motor HP 6 Motor 6 HP	#	#	#	Diametro fresa - Diameter grooving cutter - Diametre fraise Durchmesser Fraese - Diametro fresa	250 mm 110 mm*	250 mm 110 mm*	250 mm 110 mm*
Gruppo incisore con lama diam. 110 mm Scoring device with blade diam. 110 mm Groupe inciseur avec lame diam. 110 mm Grupo incisor con sierra dia. 110 mm Vorritzaggregat mit saeageblatt D. 110 mm	#	#	#	Diametro incisore - Diameter scoring blade - Diametre lame inciseur - Durchmesser Vorritzsaageblatt - Diametro incisor	110 mm	110 mm	100 mm
Motore due velocità (1400 - 2800 g/m) Two-speed motor (1400 - 2800 U/m) Moteur deux vitesses (1400 - 2800 R.p.m) Motor dos velocidades (1400 - 2800 R.P.m) Motor mit 2 geschwindigkeit (1400 - 2800 U.P.m)	#	#	#	Giri fresa - Circular grooving cutter speed - Tour de la fraise Drehzahl Fraese - Rotacion fresa	5200 U/m' 7100 U/min'	5200 U/m' 7100 U/min'	5200 U/m' 7100 U/min'
Visualizzatore a LCD per tagli verticali LCD display for vertical cuts Afficheur a LCD pour coupes verticales Visualizador de LCD para cortes verticales LCD sichtgerat für senkrechtschnitte	#	#	#	Giri incisore - Circular scoring blade speed - Tour de la lame inciseur Drehzahl Vorritzsaageblatt - Rotacion incisor	7100 U/min'	7100 U/min'	7100 U/min'
Visualizzatore a LCD per tagli orizzontali LCD display for horizontal cuts Afficheur a LCD pour coupes horizont. Visualizador de LCD para cortes horizont. LCD sichtgerat für waagrechtschnitte	#	#	#	* con "SCU" e incisore - with "SCU" and scoring - avec "SCU" et inciseur mit "SCU" und Vorritzsaageblatt - con "SCU" y incisor			
Dispositivo di tagli angolari "Angol II" - "Angol III" "Angol II" - "Angol III" angular cutting device Dispositif de coupes d'angle de "Angol II" - "Angol III" Dispositivo de cortes angulares "Angol II" - "Angol III" Vorrichtung für winkelschnitte "Angol II" - "Angol III"	#	#	#	I dati tecnici rappresentano valori indicativi. La G.M.C. SRL si riserva di apportare modifiche alle proprie macchine, in seguito ad ulteriori sviluppi e migliorie. Le macchine illustrate possono comprendere parzialmente accessori a richiesta, che non ap- partengono alla fornitura standard delle macchine. G.M.C. SRL reserves the right to make changes to its machines, following further development and improvements. The machines illustrated may partially include optional accessories not supplied as standard. Les caracteristiques techniques sont des valeurs indicatives. La G.M.C. SRL se reserve le droit d'apporter a ses machines, les modifications et a meliorations quelle jugera utiles. Les machines illustrees peuvent comprendre partiellement des accessoires en option, qui ne sont donc pas compris dans la fourniture standard des machines. Die technischen Daten stellen richtungswiesende Werte dar. Die Firma G.M.C. SRL behält sich das Recht vor, seine Maschinen, infolge von Weiterentwicklungen und Verbesserungen abzuän- dern. Einige der abgebildeten Maschinen können auf Wunsch erhältliche Zubehöerteile umfassen, die nicht zur Standardlieferung der Maschinen gehören. Los datos técnicos representan valores indicativos. G.M.C. SRL se reserva la aportación de modificaciones a las propias maquinas para obtener posteriores y mejoras. Las maquinas ilustradas pueden incluir parcialmente accesorios sobre pedido, que no estan incluidos en la dotación standard de las maquinas.			
Sistema di aspirazione "DPS" Total dust exhauster "DPS" Systemediaspiration totale DPS Sistema de aspiración total "DPS" Voelliges absaugsystem DPS	-	#	#				
Bloccaggio trave con micro di sicurezza Beam lock with safety micro Blocage poutre avec micro de securite Bloqueo travesa con micro de seguridad Tragerblockierung mit sicherheitsmikroschaft.	#	#	#				
Disp. raffreddamento metodo "Venturi" "Venturi" method cooling device Disp. refroidissement methode "Venturi" Disp. enfriamiento método "Venturi" Kühlungsvorrichtung "Venturi" methode	#	#	#				